BRISTAN

Artisan Professional Mixer

Fitting Instruction & Contents List



Please keep these instructions for future reference and request of replacement parts

Contents

Thank you for choosing Bristan, the UK's leading taps and showers expert. We have designed this product with your enjoyment in mind. To ensure that it works to its full potential, it needs to be fitted correctly. These fitting instructions have been created to give you all of the information you need and, if you need any further help, please do not hesitate to give us a call on 0330 026 6273.

Important Safety Information	03
General Specifications	04
Installation Requirements	04
Installation	05
Maintenance	06
Guarantee	07

Important Safety Information

- Please read these instructions thoroughly and retain for future use.
- All products manufactured and supplied by Bristan are safe provided they are installed, used correctly and receive regular maintenance in accordance with these instructions
- **If you are in any doubt about your ability to install this product safely you must employ the services of an experienced qualified plumber.**
- Remove all packaging and check the components for damage before starting installation.
- This product **must** not be modified in any way as this will invalidate the guarantee.
- These fittings need to be installed in accordance with and meet the requirements of the Water Supply (Water Fittings) Regulations 1999 and Scottish Byelaws 2004.

Warning from your water Supplier

- **It could be a criminal offence to use this tap with a mains water supply drawn directly from the supply pipe.**
- (The supply pipe is the one which brings the water supply into your home and is directly connected to the public water main).
- This tap has an outlet on a flexible hose which, if immersed in water, could result in contaminated water being drawn back into the pipework if the supply pressure dropped. To prevent contaminated water being drawn back into the pipework if the supply pressure dropped. To prevent contamination of drinking water in the premises and in the water main, and to comply with the legal requirement of the UK plumbing regulations and byelaws*, **both hot and cold water supplied to this tap must come from a storage cistern.**
- If the distributing pipes feeding this tap from the storage cistern have other outlets connected to them, the outlet of this tap must be lower than any of those other outlets.
- If installed as a tap which is used for drawing water for drinking, and the quality of water from the storage cistern does not meet the standards for drinking water, a separate tap supplied with wholesome water must be provided for drinking purposes.
- For further information, contact the Water Regulations department of your local Water Supplier (see WRAS website www.wras.co.uk or Yellow Pages for details) or the Water Regulations Advisory Scheme by e-mail (info@wras.co.uk) or telephone: 01495 248454.
- The Water Supply (Water Fittings) Regulation 1999 in England and Wales; The Scottish Water Byelaws 2004 and Northern Ireland Regulations.

General Specifications

	Min	Max
Operating pressure range (bar)	0.5	5.0

Maximum static pressure – 10.0 bar

NOTE:- Nominally equal (balanced) inlet supply pressures are recommended for optimum Performance of mixer taps. If pressures are unequal, then a pressure reducing valve should be used.

Designed to comply with BS EN 200 for single taps/ combination taps for water systems of type 1 and 2 general technical specifications and to be used within systems designed to BS 6700.

BS 6700 recommends the temperature of stored water should never exceed 65°C. A stored water temperature of 60°C is considered sufficient to meet all nominal requirements and will minimise the build up of lime scale in hard water areas.

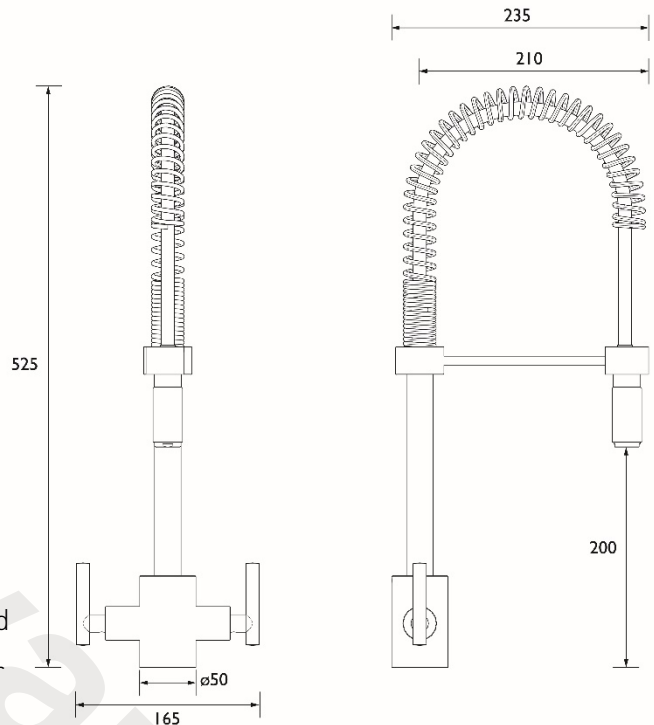

Installation Requirements

IMPORTANT - PLEASE READ

This/these fitting/fittings needs/need to be installed in accordance with the following Installation Requirements and Notes (IRN) to ensure they meet the requirements of the Water Supply (Water Fittings) Regulations 1999 and the Scottish Byelaws 2004.

IRN R001 - See text of entry for Installation Requirements or Notes.

IRN R006 - This tap or combination tap assembly has a Type AUK3 air gap and is therefore for installation in any premises to protect against a backflow risk up to a Fluid Category 5.

IRN R010 - Water supplies shall be a reasonably balanced pressures from a common source (e.g. hot and cold supplies both from the same storage or both from a supply pipe). Where the fitting is supplied from unbalanced supplies (e.g. hot and cold supplies from separate sources) a 'Listed' single check valve or some other no less effective backflow prevention device shall be fitted immediately upstream of both hot and cold water inlets.

Installation

Important: If the fitting is installed at low pressure (tank fed), then the minimum distance from the underside of the water outlet to the cold water tank should be at least 5 metres to ensure adequate performance.

This mixer should be installed in compliance with Water Regulations. For further details please contact your local Water Authority.

1. Identify all components are present prior to starting installation.
2. Install the mixer body (3) to the sink.
3. Screw the fixing rod (6) into the bottom of the mixer body (3).
4. Slide the fixings (7) onto the threaded rod (6) up to the underside of the sink.
5. To secure the mixer in place tighten the fixing nut included in the fixing kit.
6. Screw in the flexible connecting pipes (5) by **hand only (DO NOT OVERTIGHTEN)**.
7. Connect the hot and cold water supplies to the flexible connecting pipes (5).
8. Turn on both water supplies, and operate the handles in both directions letting the water flow for a few minutes to check all joints and connections for any leaks.

- | | |
|------------------------------|----|
| 1. Arm | x1 |
| 2. Spout | x1 |
| 3. Body | x1 |
| 4. Handles | x2 |
| 5. Flexible Connecting Pipes | x2 |
| 6. Threaded Rod | x1 |
| 7. Fixing Kit | x1 |

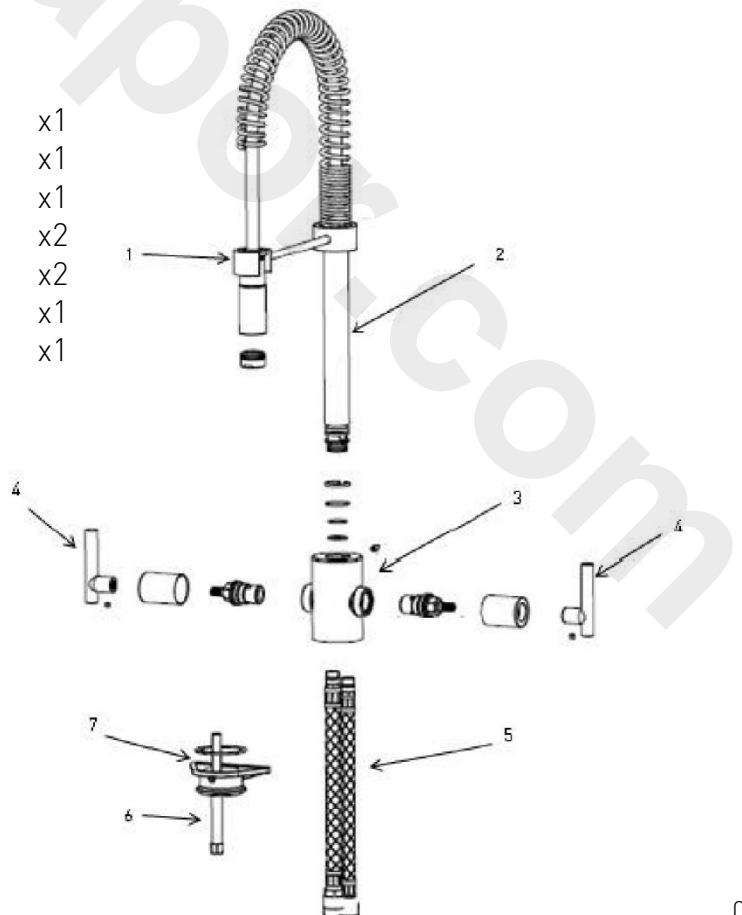

Maintenance

General Cleaning

Your fitting has a high quality finish and should be treated with care to preserve the visible surfaces. All finishes will wear if not cleaned correctly. The only safe way to clean your product is to wipe with a soft damp cloth. Stains can be removed using washing up liquid. All bathroom cleaning products (powders and liquids) will damage the surface of your fitting, even the non-scratch cleaners.

Note: Never use abrasive detergents or disinfectants or those containing alcohol, hydrochloric acid or phosphoric acid.

Maintenance

We advise that your fitting is regularly serviced in hard water areas to maintain optimum performance.

If your fitting begins to leak the following should be carried out.

Isolate both hot and cold water supplies to the mixer valve by either:

- Turning the water supply off at the mains stopcock or
- Turning off the isolation valves to the mixer valve.

1. Unscrew the grub screw (1) on the underside of the handle (2).

2. Pull the handle off to reveal the valve (3).

3. Unscrew the valve carefully clean the valve and valve seating

4. If necessary replace the valve

5. Fit the valve back into the tap body and tighten fully using a suitable spanner

6. Push the handle back onto the valve spindle and replace the grub screw (1) and tighten on the underside of the handle (2).

If the problem persists please contact our customer services helpline quoting the product code.

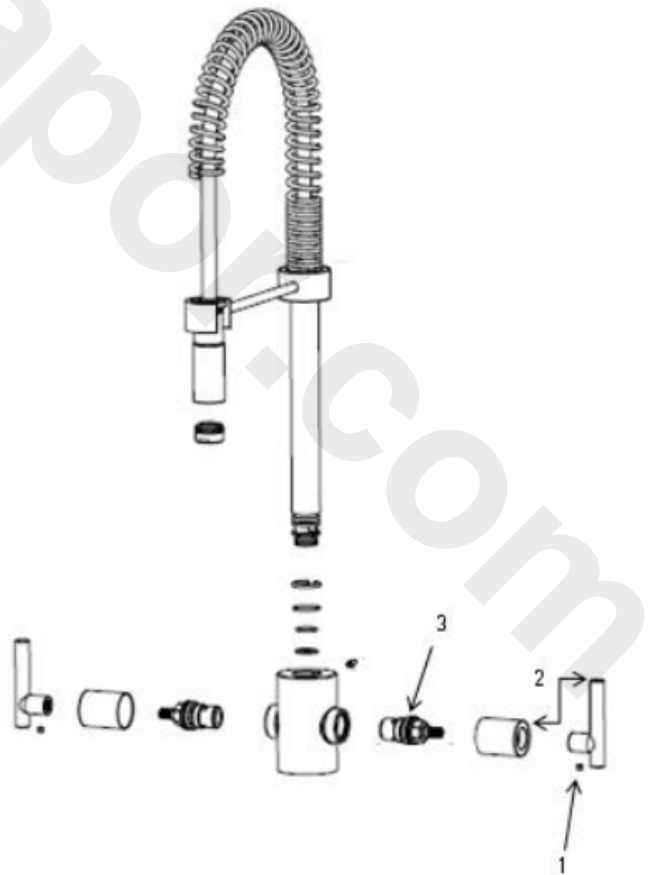

BRISTAN

Bristan Guarantee

At Bristan, we want to make things as easy as possible for our customers. That's why we offer solid guarantees on all our products, effective from the date of purchase, to give you peace of mind.

To start your free guarantee, simply scan the QR code and register your product.

Alternatively, visit www.bristan.com/register to register your product via a computer.

For full guarantee terms and conditions visit, www.bristan.com/guarantees



We Know & We Care

BRISTAN

This booklet covers product code
AR SNKPRO C

Helpline

0330 026 6273

Bristan Group Limited

Birch Coppice Business Park, Dordon, Tamworth, Staffordshire B78 1SG

A Masco Company

Website: www.bristan.com

Telephone: 0330 026 6273

Email: enquire@bristan.com